



Greyline

AVFM 6.1

Ultrasonic flow monitor for partially filled pipes & open channels.

Measures Velocity & Level to Monitor Flow with a Single Ultrasonic Sensor

Area-Velocity Flow Meter

Measure flow through open channels, partially full pipes, and surcharged pipes without a flume or weir. Ideal for wastewater stormwater, effluent, industrial wastewater, and irrigation water.

Submersible Ultrasonic Sensor

The AVFM 6.1 uses a submerged ultrasonic sensor to continuously measure both velocity and level in the channel. The sensor resists fouling, corrosion, and abrasion. The flow meter can be configured with the standard submerged velocity-level sensor, or with submerged velocity plus a separate non-contacting ultrasonic level sensor, for highly aerated fluids or those with a high concentration of suspended solids.

View flow rate and total flow on the large backlit LCD display and connect to external devices with three 4-20mA outputs and two control relays. Flow rate, volume, run hours, and diagnostic information available through the optional Modbus RTU serial communications.

Ultrasonic Flow Monitor for Partially Filled Pipes & Open Channels

Easy to Use

The AVFM 6.1 Area-Velocity Flow Meter measures both level and velocity to calculate flow in an open channel or pipe. Configuration is simple: enter the pipe diameter or channel dimensions and the AVFM 6.1 automatically computes and displays flow volume.



THE RIGHT METER FOR

- Wastewater
- Industrial Effluent
- Stormwater
- Combined Sewers
- Natural Streams
- Irrigation Water

The ultrasonic sensor mounts inside the pipe or on the bottom of a channel with a stainless steel mounting bracket (included) and a single screw into the bottom of the pipe or channel. No special compounds, tools, or hardware are required. The sensor is completely sealed with no orifices or ports.

Recommended Pipe or Channel Conditions

Careful selection of sensor mounting location results in the best performance and maintenance-free operation. Avoid locations where sediment builds up.



Sales & Support
(435)755-0774
www.inmtn.com

The best possible accuracy will result when the water is not highly turbulent and where velocity is evenly distributed across the channel. The channel should not have drops or direction changes immediately upstream of the sensor mounting location. Pipe or channel slope should not exceed 3%. See the installation manual for specific installation recommendations.



The AVFM 6.1 can measure forward flow velocity up to 6 m/s (19.7 ft/s) and reverse flow up to 1.5 m/s (5 ft/s). The electronics and software sample and average flow rates continuously to provide stable readings. The submerged velocity / level sensor will measure flow in partially full and surcharged pipes with pressure up to 10 psi. No special setup or adjustment is required. The minimum recommended pipe diameter is 150 mm (5.9 in).

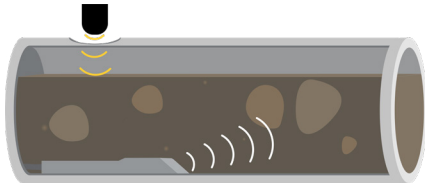

Alternate Sensor Configurations

Alternate sensor models are available for special applications: a separate non-contacting ultrasonic level sensor with a submerged velocity sensor. The sensor cable can be extended up to 152.4 m (500 ft). Use this configuration for pipes or channels with a high concentration of air or suspended solids.

Custom Channel Shapes

Configure the AVFM 6.1 for installation in irregular or compound channel shapes by entering the channel width at multiple level points through a simple menu. Channels of virtually any shape can be monitored with your choice of measurement units.



Standard 26 Million Point Data Logger

The AVFM 6.1 will store time and date-stamped flow values at 10-second to 60-minute intervals. Daily flow reports are automatically created where total, minimum, maximum, and average flow rates are displayed on the LCD display. Transfer log files and daily flow reports to any USB flash drive just by connecting to the logger's USB output. Windows software is included to display log files in graph and table formats, change measurement units, and generate flow reports. Or, download data as .csv file format for import directly to Microsoft Excel.

Greyline AVFM 6.1 Area-Velocity Flow Meter

- Digitally Measure flow in pipes and open channels of any shape
- Ideal where flumes or weirs are difficult to install
- Works with water level from 25.4 mm to 4.5 mm (1 in to 15 ft)
- Auto-detects field installation of options, serial communications, and control relays

The AVFM 6.1 Area-Velocity Flow Meter includes a submerged ultrasonic sensor that is installed at the bottom of an open pipe or channel. Exposed materials are stainless steel so the sensor resists fouling and corrosion, and has no moving parts, orifices, ports, or electrodes.

The AVFM 6.1 displays and totalizes flow. It includes three 4-20mA outputs (flow, level, and velocity), plus two control relays for level alarms or flow proportionate pulse output for samplers and chlorinators. It is easy to calibrate with the built-in keypad and menu system. A built-in 26 million point data logger with USB output is standard. Intrinsic safety barriers for sensor and cable installation in hazardous rated channels are also optional.

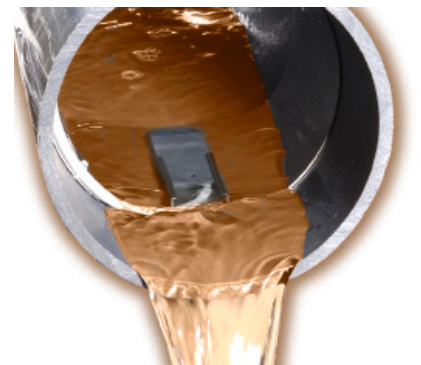

Technical Specifications

GENERAL SPECIFICATIONS

Operating Parameters:	Round pipe, rectangular, trapezoid, egg, or custom shapes
Programming:	Built-in 5-key calibrator with English, French, or Spanish language selection
Electronics Enclosure:	NEMA4X (IP66) polycarbonate with clear, shatterproof cover
Accuracy:	<ul style="list-style-type: none">Level: $\pm 0.25\%$ of reading or ± 2.03 mm (0.08 in), whichever is greater. Repeatability & Linearity 0.1%.Velocity: $\pm 2\%$ of reading or ± 0.012 m/s (0.04 ft/s), whichever is greater. Requires solids or bubbles minimum size of 100 microns, minimum concentration 75 ppm. Repeatability & Linearity 0.5%
Display:	White, back-lit matrix — displays flow rate, totalizer, relay states, operating mode, and calibration menu
Power Input:	<ul style="list-style-type: none">100-240 V AC 50/60 Hz, 10 V A maximumOptional: 9-32 V DC, 10 W maximum
Analog Output:	3 Isolated 4-20mA, 1 k Ω , (flow, level, and velocity) or 0-5 V DC by menu selection
Control Relays:	2 Relays, form 'C' dry contacts rated 5 A SPDT; programmable flow alarm and/or flow proportional pulse (sampler/totalizer), flow and/or level alarm
Data logger:	Programmable 26 million point data capacity, time and date stamped plus formatted flow reports including total, average, minimum, maximum, and times of occurrence. Includes USB output to Flash Drives and Windows software.
Operating Temp. (Electronics):	-20 °C to 60 °C (-5 °F to 140 °F)
Approximate Shipping Weight:	4.5 kg (10 lb)
Approvals:	CE, CSA/UL/EN 61010-1

TRANSDUCER SPECIFICATIONS

Transducer:	QZ02L submersible sensor measures level and velocity
Level Measurement Range:	<ul style="list-style-type: none">Minimum Head: 25.4 mm (1 in)Maximum Head: 4.6 m (15 ft)
Velocity Measurement Range:	0.031 m/s to 6.2 m/s (0.1 ft/s to 20 ft/s) and reverse flow to -1.5 m/s (-5 ft/s) in fluids containing bubbles or solids with a minimum size of 100 microns and a minimum concentration of 75 ppm to act as acoustic reflectors
Operating Temperature:	-15 °C to 80 °C (5 °F to 175 °F)
Exposed Materials:	316 stainless steel, epoxy resin, polyurethane
Transducer Cables:	7.6 m (25 ft) submersible polyurethane jacket, shielded, 3-coaxial
Transducer Mounting Kit:	Includes MB-QZ stainless steel mounting bracket
Temperature Compensation:	Automatic, continuous

POPULAR OPTIONS

Industrial Automation Protocols:	Modbus RTU via RS485
Transducer Cables:	15.2 m or 30.5 m (50 ft or 100 ft) submersible, continuous from sensor — or splice up to a total of 152.4 m (500 ft) lengthlength
Sensor Cable Junction Box	Watertight NEMA4 polycarbonate with connection terminal strip
Enclosure Heater:	Thermostatically controlled to -40 °F/°C — recommended for temperatures below 0 °C (32 °F)
Intrinsic Safety Barriers:	For sensor mounting in Class I, II, III, Div. I, II, Groups C, D, E, F, G hazardous locations
Transducers:	Separate non-contacting ultrasonic level sensor and submerged velocity sensor
Sensor Mounting Bands:	Stainless steel sensor mounting bands for pipes 152.4 mm to 1.8 m (6 in to 6 ft) diameter

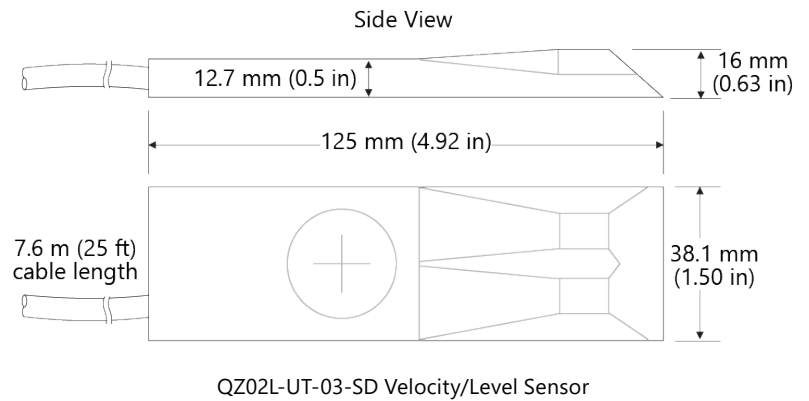
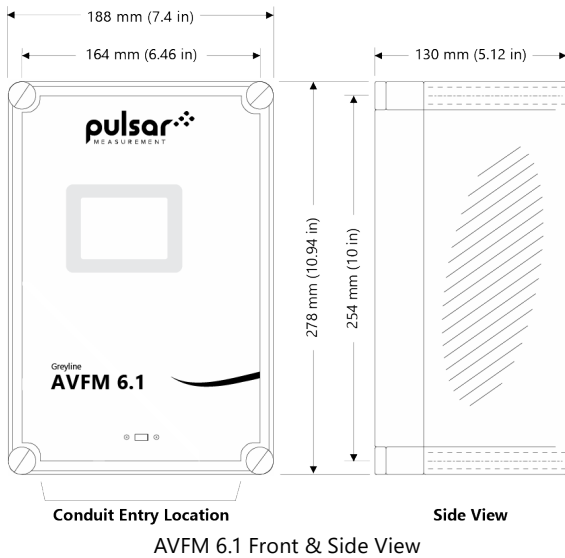

Delivering the Measure of Possibility

Pulsar Measurement offers worldwide professional support for all of our products, and our network of global partners all offer full support and training. Our facilities in Malvern, UK and Largo, USA are home to technical support teams who are always available to answer your call or attend your site when required. Our global presence, with direct offices in the UK, USA, Canada, and Malaysia, allows us to create close relationships with our customers and provide service, support, training, and information throughout the lifetime of your product.

By taking a step forward in echo processing technology, Pulsar Measurement addresses applications previously thought to be beyond the scope of ultrasonic measurement. This technology improves signal processing at the transducer head which has made it possible to increase resistance to electrical noise, enabling the transducer to 'zone in' on the true echo.

For more information, please visit our website:

www.pulsarmeasurement.com



INFO@PULSARMEASUREMENT.COM

Pulsar Measurement is a trading name of Pulsar Process Measurement, Ltd.

*Copyright © 2021 Pulsar Measurement
Registered Address: 1 Chamberlain Square CS, Birmingham B3 3AX
Registered No.: 3345604 England & Wales*

United States
+1 888-473-9546

Asia
+60 102 591 332

Canada
+1 855-300-9151

Oceania
+61 428 692 274

United Kingdom
+44 (0) 1684 891371

pulsarmeasurement.com